



MODULAR 4-WAY BLEED PILOT VALVES

R-441



4-Way Valve

Features:

- Indicator shows valve in shaded position
- Micro gap construction - snap action and no blow by
- Balanced design allows speed control at exhausts

Performance:

Flow: 9 scfm @ 100 psig; 255 l/min @ 6.9 bars
Pilot Pressure Minimum: 40 psig; 2.8 bars
Temperature: 32° to 180° F
Working Pressure: 0 to 150 psig; 0 to 10.3 bars

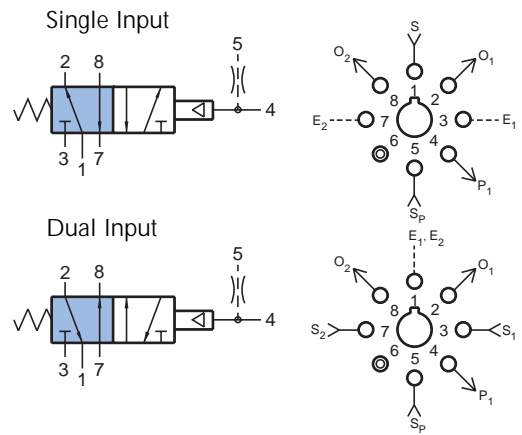

Description:

R-441 is a 4-way, spring return, bleed piloted valve for use with simple low force sensors. The vent supply pressure is independent of the inlet pressure to the valve. This pilot supply passes through a built-in restriction and shifts the valve compressing the spring. Venting (exhausting) the pressure in the pilot chamber (faster than the restricted supply can recover) shifts the valve.

R-442



4-Way Valve

Features:

- Indicator shows valve in shaded position
- Micro gap construction - snap action and no blow by
- Balanced design allows speed control at exhausts

Performance:

Flow: 9 scfm @ 100 psig; 255 l/min @ 6.9 bars
Pilot Pressure Minimum: 20 psig; 1.4 bars
Temperature: 32° to 180° F
Working Pressure: 0 to 150 psig; 0 to 10.3 bars

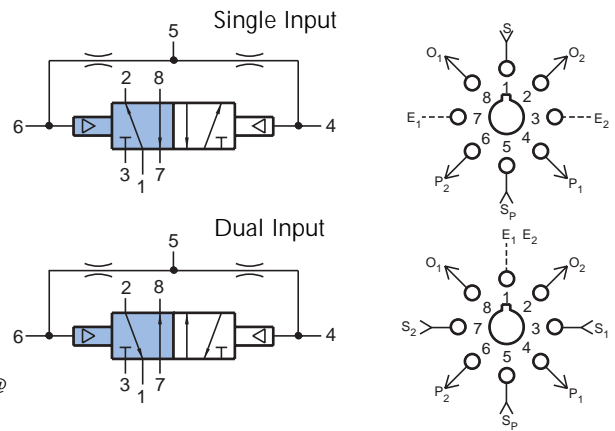

Description:

R-442 is a 4-way, double bleed pilot valve. The vent supply pressure is independent of the inlet pressure to the valve. Pilot supply passes through built-in restrictions and pressurizes both pilots. Venting (exhausting) the pressure in one pilot chamber (faster than the restricted supply can recover) causes the valve to be shifted by the opposite pilot.